

INTU
EVOLUTION

Installation & User Guide

PERFORMANCE ON DEMAND

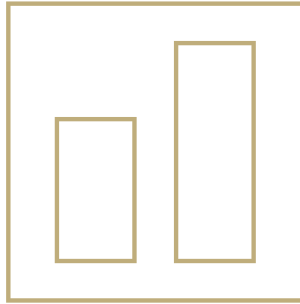

INTU
EVOLUTION

ANOTHER GREAT
PRODUCT BY

INTU
YOUR HOME

WWW.INTUYOURHOME.CO.UK

WELCOME TO YOUR
BRAND NEW



ELITE

4-1 BOILING WATER TAPS

IMPORTANT NOTICE:

When correctly installed and maintained with care, your INTU Evolution boiling water tap will give you many years of trouble free service. **This product is not for outdoor use.** This product can cause harm if installed incorrectly. It is recommended that the installation of your instant hot water tap is carried out by a professional installation service.

Please read and fully understand all installation instructions before installing and using this application. If in doubt contact a qualified plumber or retailer to assist.

Check that no parts are missing or damaged. If parts are missing do not install and contact our customer services.

A standard 220/240v grounded 13 amp switched electrical outlet is required under the sink for the appliance electrical power. The instant hot water INTU tank is only intended for use with compatible INTU boiling water taps. Using this tank with any other tap will invalidate the warranty.

Do not plug in the tank until all water connections have been checked, watertight and the tank has been filled. The tank is filled once water starts to pass out the tap spout. It is recommended before using the tank, to flush through several litres of water to remove any air in the system when installing.

Please note, that in order to avoid having pressurised boiling water and to comply with UK byelaws, this is an open vented system. In order to ensure the instant hot water INTU tank delivers the highest quality drinking water and is protected from limescale build up, **the water filter must be replaced every 6 months.** Failure to do so may invalidate your product warranty.

Optional Extra : Pressure Reducing Valve

A Water Pressure Reducing Valve is available which is recommended for use in areas where high water pressure in the water supply to your property may become an issue. If you have any questions about the water pressures supplied to your property please contact a registered plumber or contact your local water authority.

Contact us at enquiries@intuevolution.co.uk or these can be purchased online at www.theboilingwatertapcompany.com or by calling 01772 923 849



- + To prevent against electrical shock do not place the hot water tank near or in water or other liquids and install on a flat surface.
- + Do not install in environments above 35°C or exposed to freezing.
- + Can be used by children 12+ or people with learning difficulties if they have been given supervision or instructed on the hazards involved.
Do not operate or install electrical connections with wet hands
- + Do not install the appliance if it appears damaged in any way
- + Only use power lead supplied with the product. If the power lead is damaged, stop using immediately and contact customer services for a replacement.
- + Do not remove tank casing, this product is not serviceable and should be returned to the manufacturer in the event of a fault.
- + Do not modify the tank or remove the plug as this will invalidate the warranty and could cause serious injury. Design for UK 3 pin socket only.
- + If the unit is unused for extended periods of time it should be unplugged, drained, re-filtered and refilled.
- + The tap and water tank can be cleaned with a lint free damp cloth.
Do not use any abrasive or corrosive cleaning products as this will damage the surface of the product.
- + Replace the filter every 6 months



ELITE

4-1 BOILING WATER TAPS

- | | | | | | |
|----|----------|----------------------------|----|----------|----------------------------|
| x1 | A | Faucet | x1 | I | Cold Water Supply Hose |
| x1 | B | Rubber Washer | x1 | J | Drinking Water Outlet Hose |
| x1 | C | Rubber Gasket | x1 | K | Boiling Water Supply Hose |
| x1 | D | Metal Washer | x1 | L | Boiling Water Outlet Hose |
| x1 | E | Mounting Nut | x1 | M | Plastic Aerator Wrench |
| x1 | F | Three-way Connector | | | |
| x1 | G | Drinking Water Supply Hose | | | |
| x1 | H | Hot Water Supply Hose | | | |

ELITE

4-1 BOILING WATER TAP

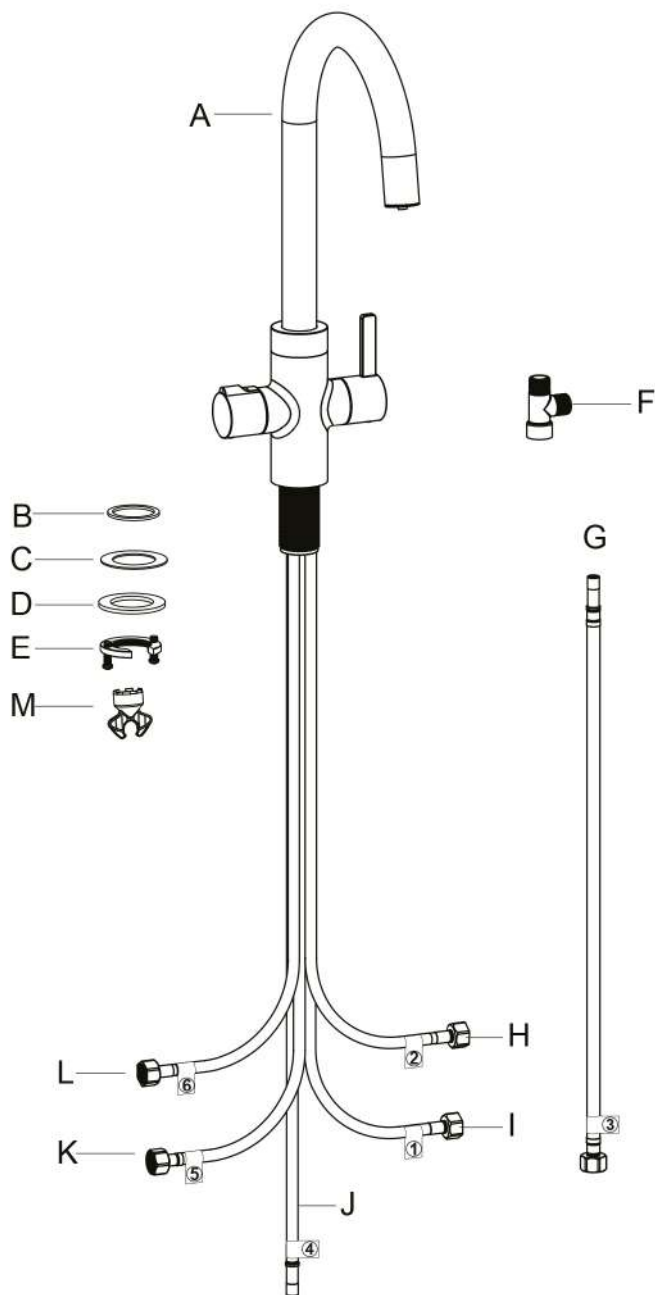

ELITE

4-1 BOILING WATER TAP

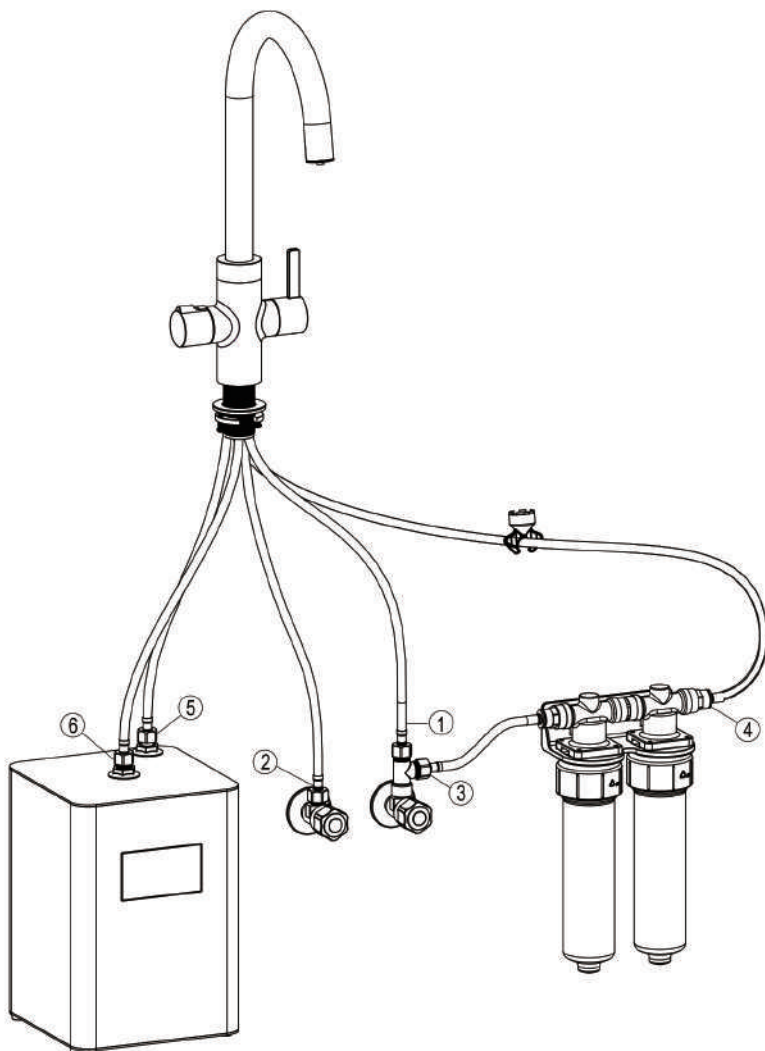

TOP TIP : Pass the 4 hoses with nuts through the surface hole first and then pass the 1 hose without nuts to help with your installation.

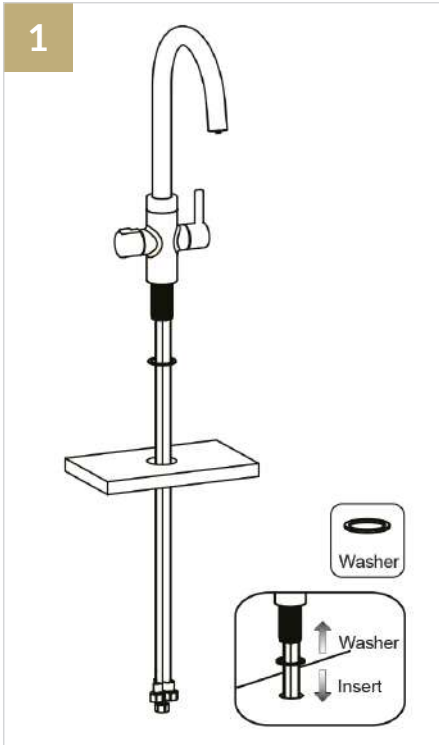

Insert the Rubber Washer (B) over the hoses into the faucet shank and mount the faucet on the basin. See Fig 1

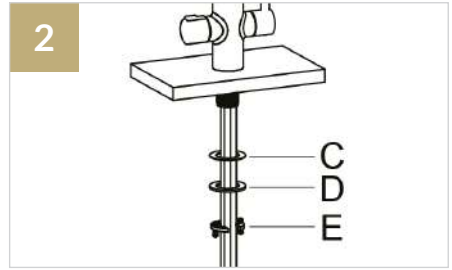

Firstly slide the Rubber Gasket (C) over the hoses, followed by the Metal Washer (D) and then the Mounting Nut (E) onto the stem. Hand tighten them firmly. See Fig 2

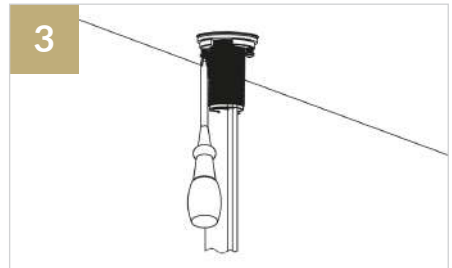

Use a Phillips head screwdriver to thread the 2 screws. See Fig 3

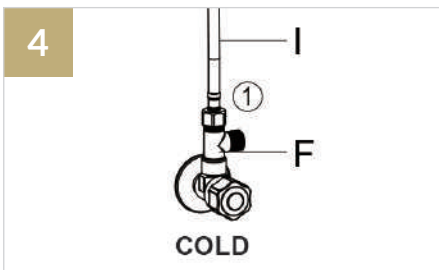

Connect the Three-way connector (F) onto the cold water valve. Connect the Cold Water Supply Hose (I) (1) onto the Three-way connector. Secure with an adjustable wrench. See Fig 4

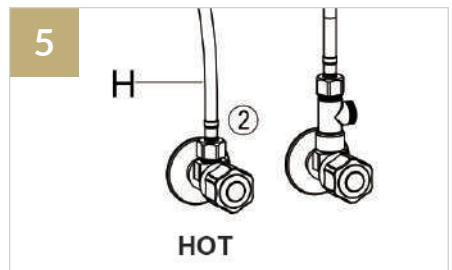

Connect the Hot Water Supply Hose (H) (2) onto the hot water valve. Secure with an adjustable wrench. See Fig 5

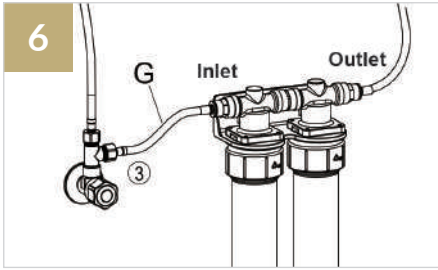

Connect the Drinking Water Supply Hose (G) (3) onto the other side of the Three-way Connector, and secure the connection with an adjustable wrench. Fit the other end of the hose (G) into the filter housing inlet. See Fig 6

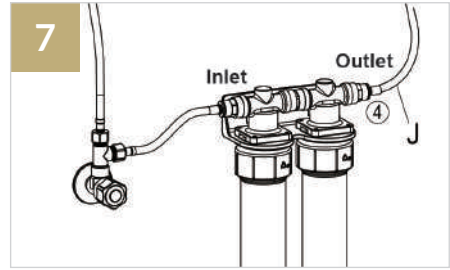

Fit the Drinking Water Outlet Hose (J) (4) into the filter housing outlet. See Fig 7

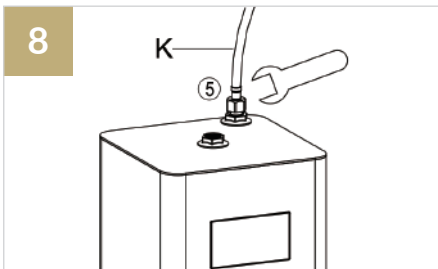

Connect the Boiling Water Supply Hose (K) (5) onto the **blue** inlet on the boiling water tank. Secure the connection with an adjustable wrench. See Fig 8

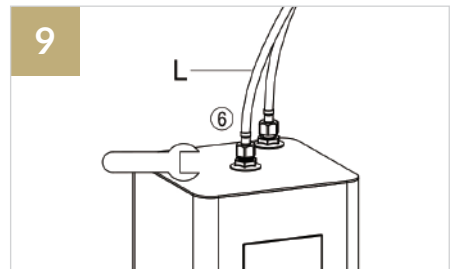

Connect the Boiling Water Outlet Hose (L) (6) onto the **red** outlet on the boiling water tank. Secure the connection with an adjustable wrench. See Fig 9

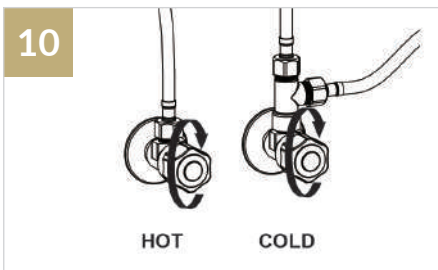

Turn on the water supply. Test systems for leaks and purge system. Run a minimum of 10 litres of water through the tank to remove any air. See Fig 10

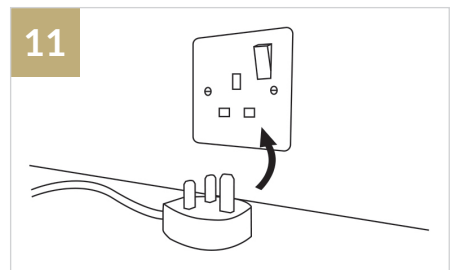

Your installation is now completed. Hang the plastic aerator wrench (M) on one of the hoses for future use. Plug tank into power outlet and switch on. The power indicator will flash. See Fig 11

ELITE

4-1 BOILING WATER TAP

HOW TO USE YOUR 4-1 BOILING WATER TAP

- (i) For filter boiling water slide the left handle flat button to the left. Keep the button pressed and rotate the handle forwards
- (ii) For filtered cold water rotate the handle away from you
- (iii) For mixed domestic water use the lever on the right

REGULATION REQUIREMENTS:

It is important to ensure that the water supply to your tap is connected in accordance with the water regulation requirements, plumbing code and good plumbing practice. It is good practice that the supply of hot and cold water to the tap are equal (balanced) pressure in order to provide a consistent flow. Water supply should be from a common source, either mains or tank fed. If the water supply is not equal pressure then a Non Return Valve (check valve) should be fitted on the hot inlet.

WATER SUPPLY PRESSURES:

This tap has been designed to function under the following conditions:

- + Minimum supply pressure for cold water is 1.5 bar Maximum supply pressure 5 bar (although we only recommend a Maximum supply pressure of 3.0 bar)
- + Should excessive pressure be experienced then it is recommended to install a Pressure Reducing Valve.

IMPORTANT - CARE AND MAINTENANCE OF THE TAP:

Only clean the tap with a soft cloth, warm water and a mild detergent solution. Rinse the tap clean thoroughly afterwards with water. Do not use any abrasive or harsh chemical products, otherwise this will invalidate your guarantee.

The filter needs changing every 6 months. This is very important for continued running of your system. Failure to do so may damage the unit and invalidate your warranty.

These instructions are only intended as a guide, if there is any doubt then contact a certified plumber or service agent and avoid using the Instant Hot Water System until it has been checked.

LUXE

BOILING WATER TANK

OPERATION INSTRUCTIONS - INSTANT HOT WATER TANK



1. Power touch button
2. Heat increase touch button
3. Heat decrease touch button
4. Heating function active indicator
5. Heating to temperature indicator
6. Water temperature 'READY' indicator
7. Filter status indicator

INSTRUCTIONS:

- (i) Press and hold power touch button (1) for **three seconds**.
- (ii) The LCD will illuminate and 'HEATING' will be illuminated red (4)
- (iii) Set heating temperature using + and - touch buttons (2 & 3)
- (iiii) When tank is at desired set temperature 'READY' will illuminate and the tap is ready for use (6)

NOTE: Using the + and - buttons of the screen, the tank can be preset to 55°C, 65°C, 75°C, 85°C, 90°C, 95°C, 96°C, 97°C or 98°C.

LUXE

BOILING WATER TANK

RESETTING THE FILTER INDICATOR AFTER FILTER REPLACEMENT:

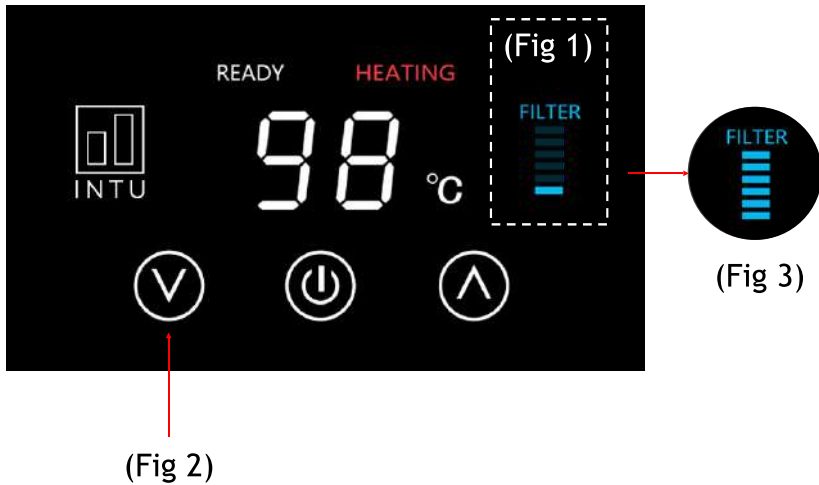

After replacing the instant hot water filter, the filter indicator light on the tank display (Fig 1) will need to be reset to continue use.

To reset, press and hold - temperature button (Fig 2) for **four seconds** until light is fully illuminated (Fig 3)

INTU

TROUBLESHOOTING

Problem	Likely Fault(s)	Solution
Water and steam spitting from tap.	Unit is boiling.	Reduce the water temperature on the tank display to a lower setting. Check aerator is not blocked by unscrewing top nozzle. Aerator should be detached from silicone tube and cleaned if required.
Unit not heating.	Issue with power supply.	Make sure the fuse has not blown, or circuit breaker tripped.
Unit not heating.	The electronic display has not been powered up.	Turn on power and touch the on/off button. Set the required temperature using + or - button.
Dispensed water is too hot.	Water temperature setting on display panel is set too high.	Reduce required temperature using - button.
Water is dripping from the tap.	The expansion chamber isn't draining the system correctly due to very small draw off of water.	Draw off 0.5L of water to clear and prime the system. Avoid less than 150ml draw-offs of water.
Slow flow from the spout.	Water filter may be blocked from impurities in the inlet mains water.	Replace filter cartridge.
Water does not flow straight away.	The application is designed for non-pressurised operation which will cause a slight delay before water is dispensed.	No action required.
No water coming from the tap.	Water valve have been shut off.	Check all the valves are open.
No water coming from the tap.	Inlet pipes are twisted or blocked.	Ensure the pipes are not twisted or kinked to restrict flow. Check aerator is not blocked by unscrewing top nozzle. Aerator should be detached from silicone tube and cleaned if required.



INTU
EVOLUTION

CUSTOMER CARE

UK Freephone: 01772 923 849

Email: enquiries@intuevolution.co.uk

www.intuevolution.co.uk

www.intuyourhome.co.uk